



Accessories

PBS SIPs Mastic

Premier SIPs mastic referred to on our plans and in our specifications is supplied by Premier Building Systems with your order. Premier's SIPs mastic has been specifically formulated to help seal Premier SIPs connections. Consisting of polymers that are designed to remain flexible, Premier's mastic provides a seal against water vapor transmission and air infiltration. Premier's SIPs mastic should be installed according to Premier Building Systems' recommended installation guidelines.



ADVANTAGES

- Sealant for all types of SIPs construction
- Permanent, non-brittle formula
- Gunable at low temperatures
- Withstands cold and freeze-thaw cycles
- Retains flexibility with age
- Resistant to moisture, dampness and temperature fluctuation
- Impervious to water wash-out
- Seals foam, wood products and many other materials

Panel Size	Recommended Amount of SIPs Mastic (29 oz. Tubes)
4' x 8'	0.91
4' x 10'	1.06
4' x 12'	1.22
4' x 16'	1.52
4' x 20'	1.82
4' x 24'	2.13
8' x 8'	1.22
8' x 10'	1.37
8' x 12'	1.52
8' x 16'	1.82
8' x 20'	2.13
8' x 24'	2.43

This chart has been calculated with a 3/8" diameter bead on wood-to-foam and foam-to-foam interfaces and a 3/16" diameter bead on wood-wood interfaces

Accessories

PBS SIPs Zero-VOC Mastic

Premier SIPs Zero-VOC mastic is an environmentally conscious mastic option available with your Premier



Building Systems projects. Specifically formulated to seal Premier SIPs connections, the Zero-VOC mastic option consists of polymers that are designed to remain flexible, provide a seal against water vapor transmission, and against air infiltration. Premier's Zero-VOC mastic should be installed according to Premier Building Systems' recommended installation guidelines.

ADVANTAGES

- Environmentally conscious Zero-VOC sealant for all types of SIPs construction
- Helps earn valuable LEED and Green certification points
- Permanent, non-brittle formula retains flexibility with age
- Gunable at low temperatures and withstands cold and freeze-thaw cycles
- Resistant to moisture, dampness and temperature fluctuation
- Impervious to water wash-out
- Seals foam, wood products and many other materials

Panel Size	Recommended Amount of SIPs Mastic (20 oz. Tubes)
4' x 8'	1.32
4' x 10'	1.54
4' x 12'	1.76
4' x 16'	2.20
4' x 20'	2.64
4' x 24'	3.08
8' x 8'	1.76
8' x 10'	1.98
8' x 12'	2.20
8' x 16'	2.64
8' x 20'	3.08
8' x 24'	3.53

This chart has been calculated with a 3/8" diameter bead on wood-to-foam and foam-to-foam interfaces and a 3/16" diameter bead on wood-wood interfaces

PBS SIPs Tape

Premier SIPs tape is a patented, pressure-sensitive, highly durable and superior tape that prevents moist air from penetrating the seams between panels and along roof lines. The tape is formulated with a permeance of less than 1. The combination of the OSB skins and the SIPs tape meets the building code requirements for vapor retarders.

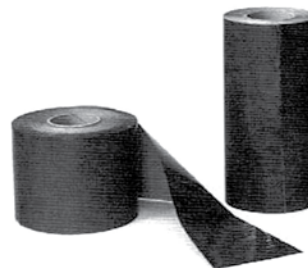

ADVANTAGES

- High peel and shear strength
- Self-healing
- VOC free
- Does not stain
- No odors or fumes; meets air quality criteria for use as an interior sealant
- In-service temperature range of -60°F to 300°F
- Quick & easy installation—no priming required
- Excellent resistance to water, most chemicals and vapor transmission

PBS SIPs Fasteners

Premier's SIPs fasteners are supplied by Premier Building Systems with your order. The fasteners were developed specifically for connecting Premier SIPs to each other, beams, purlins and posts of wood and light gauge metal.



APPLICATION

- 2x's require a minimum 1" penetration
- PBS SIPs wall-to-wall connections at corners require a minimum spacing of 2' o.c.
- PBS roof panel connections require that screws be spaced a minimum of 1' o.c.
- Frequency of screw fasteners depend on the imposed loads that the SIPs panels must resist. Follow the requirements specified on your shop drawings.

ADVANTAGES

- Corrosion resistant coating
- Excellent pull-out resistance
- State of the art tempering and coating technology
- Developed specifically for the attachment of Premier SIPs to beams, purlins, and posts of wood and light gauge metal
- The multi-lobed head reduces fastener head strip out.

LENGTHS

Steel 11 3/4"	Wood 14"
Steel 13 3/4"	Wood 15"
Steel 6"	Wood 16"
Steel 8"	Wood 5"
Steel 9 3/4"	Wood 6"
Wood 10"	Wood 7"
Wood 11"	Wood 8"
Wood 12"	Wood 9"
Wood 13"	

Premier SIPs Fastener Specifications

Diameter, Thread & Point		
	Inches	Millimeter
Head Diameter	.635"	16.13mm
Thread Diameter	.245" minimum	6.22mm minimum
Shank O.D.	.19" nominal	4.83mm nominal

Premier SIPs Fastener Length Guide (Roof Panel Size)

Pitch	4 1/2"	6 1/2"	8 3/8"	10 3/8"	12 3/8"
2/12	6"	8"	10"	12"	14"
4/12	6"	8"	10"	12"	14"
6/12	7"	9"	10"	12"	14"
8/12	7"	9"	11"	13"	15"
10/12	8"	10"	12"	14"	16"
12/12	8"	10"	12"	14"	16"

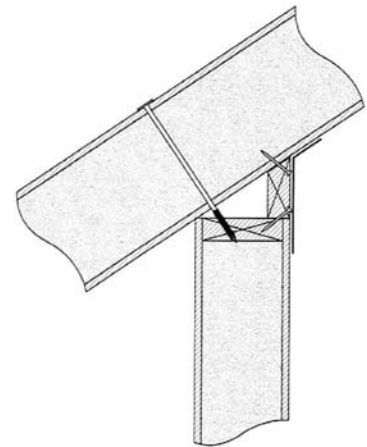

This chart will provide roughly a 1" penetration into the top plate.

Accessories

PBS Building Wrap

Get your building envelope accessories from one place. PBS's building wrap is available for you to order with your SIPs package to protect your projects for years to come.

DESCRIPTION

74 gsm micro-perforated white building wrap, 9/10' x 150' per roll

ADVANTAGES

- **Strong & Durable:** PBS building wrap is cross woven to resist tearing around fasteners and will hold-up during installation.
- **Moisture Protection:** PBS building wrap is water resistant and provides reliable protection in finished wall assemblies.
- **Breathable:** PBS building wrap is micro-perforated to allow moisture vapor to escape.
- **Stable:** PBS building wrap is treated to resist excessive degradation from normal UV exposure for up to 300 days.
- **Simple Application:** The lightweight design and familiar installation processes makes installing PBS building wrap products simple and efficient. PBS building wrap products are also translucent, making it easy to locate studs, openings, and corners.

Typical Physical Properties of PBS Building Wrap

Tensile Strength (MD/CD)	46/36 lbs/inch - ASTM D 828
Water Vapor Transmission	63 g/m ² /24 hours - ASTM E 96, Method A
Water Vapor Permeance	9 perms - ASTM E 96, Method A
Water Resistance	60 minutes - ASTM D 779



Website: www.pbssips.com

Email: info@pbssips.com

Toll Free: 800-275-7086