

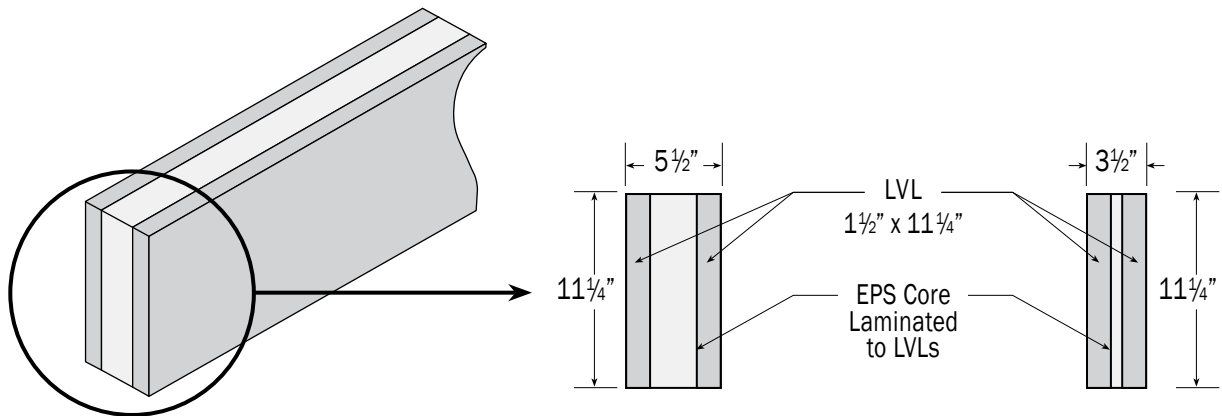

Headers

PBS INSUL-BEAM II HEADER



Insul-Beam II is a high-performance structural Header which utilizes expanded polystyrene (EPS) a closed cell, light weight resilient insulating material.

- **Environmentally Friendly.** Contains no formaldehyde or ozone-depleting CFCs or HCFCs, contains recycled material, and is 100% recyclable if ever removed or replaced.
- **Stable R-Value.** Designers are well served knowing that EPS's thermal properties will remain stable over its entire service life. There is no thermal drift, so the product is eligible for an Insulfoam 20-year thermal performance warranty.
- **Proven Performance.** The same fundamental EPS chemistry has been in use since the mid-1950s, so the actual performance of the product is well known.

Headers

INSUL-BEAM II HEADER LOADS (PLF)

No. of Trimmer Studs	Deflection	Header Span (ft.)						
		2'	3'	4'	5'	6'	7'	8'
1	L/480	3150	2100	1575	1260	1050	900	788
	L/360	3150	2100	1575	1260	1050	900	788
	L/240	3150	2100	1575	1260	1050	900	788
2	L/480	6300	4200	3150	2520	2100	1800	1545
	L/360	6300	4200	3150	2520	2100	1800	1575
	L/240	6300	4200	3150	2520	2100	1800	1575

No. of Trimmer Studs	Deflection	Header Span (ft.)							
		9'	10'	11'	12'	13'	14'	15'	16'
1	L/480	700	630	573	458	360	288	234	193
	L/360	700	630	573	525	480	384	313	257
	L/240	700	630	573	525	485	450	420	386
2	L/480	1085	791	594	458	360	288	234	193
	L/360	1400	1055	792	610	480	384	313	257
	L/240	1400	1245	792	864	720	577	469	386

Values listed for each deflection represent the least value of the bearing capacity of the trimmer, shear or bending capacity of the header or the actual deflection at the design load. Refer to Technical Bulletin #30 for supporting headers in PBS Wall SIPs (www.pbssips.com).
 Note: Trimmer stud design capacities must be reviewed.

