

HEADERS IN PREMIER BUILDING SYSTEMS WALL PANELS

Premier Building Systems Technical Bulletin #10 addresses the load carrying capacity of PBS SIP Panels used as headers and refers to the Insul-Beam header. This Technical Bulletin focuses on how to support Insul-Beam headers as well as headers constructed from an engineered wood product like LVL's or built up headers constructed from multiple plies of dimensional lumber.

Many design professionals and builders are familiar with how headers work in conventional framing when considering load distribution around openings. PBS SIP Panels act differently than conventional stick framing when load paths are considered. PBS SIP Wall Panels, typically, do not use dimensional lumber in the panels to transfer gravity loads. The OSB skins are the load transferring elements. It is for this reason that PBS requires that the OSB skins of the wall panels be completely supported.

In situations where headers, other than PBS SIP Panels are used, the headers are sandwiched between the OSB faces of the PBS SIP Wall Panel. If the header were to be placed directly above the opening, as typically done with stick construction, the only way for gravity loads to transfer to the header from the wall panel OSB faces is through shear transfer of the nails that connect the OSB faces to the header. This situation is acceptable provided it is engineered by a design professional.

For typical situations, PBS requires the built up headers be placed directly beneath the top plate of the wall and the trimmer studs extend up to the underside of the header. King studs are then added and attached to the trimmer studs as required by the structural design. By using this methodology, the built up header transfers the gravity loads to the trimmer studs through bearing and the wall panel below the header transfers the wind loading to the king studs attached to the trimmer studs. Detail PBS-201 shows this configuration for a wall.

If the header is to be placed directly above the opening, a plate, the same width as the wall panel is nailed to the top of the header which will provide bearing for the OSB skins of the panel above the header. Detail PBS-211 depicts this condition.

For gable wall situations either of the previously described methods can be used for the header. If the header is placed directly below the top plate of the gable wall panel, the ends of the header will have to be plumb cut to match the slope of the wall.

SEE DESIGN MANUAL FOR INSULBEAM II HEADER CHART

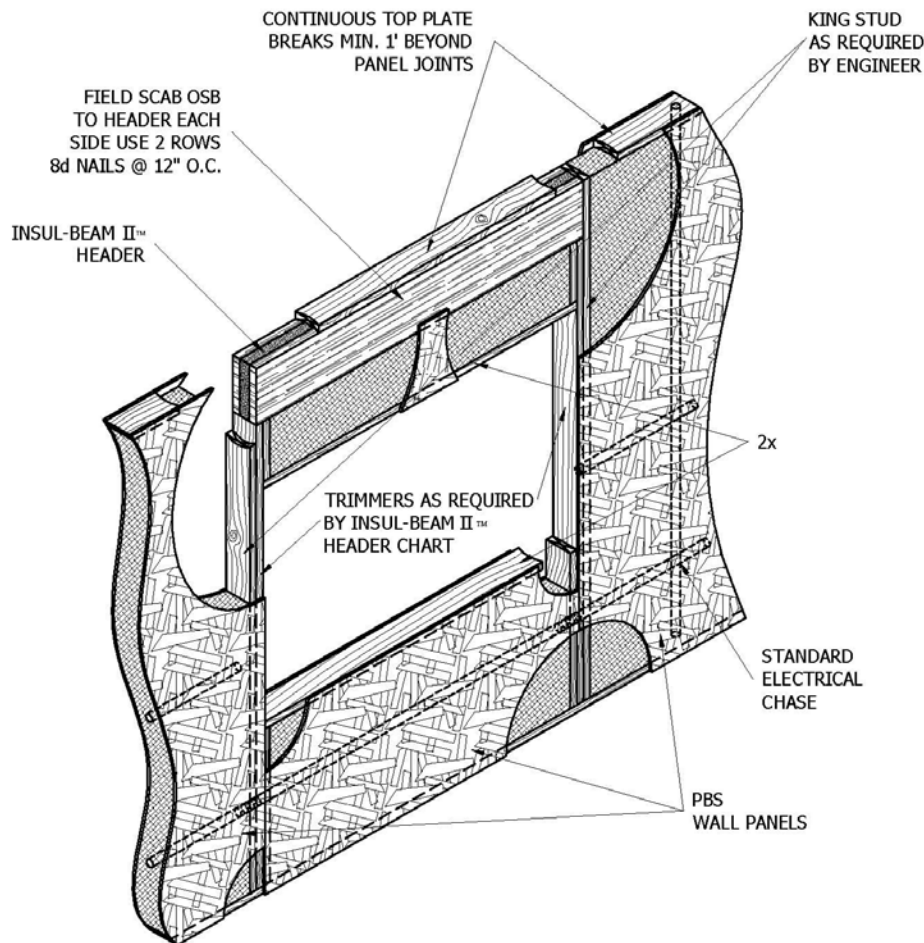

INSUL-BEAM HEADER
PREMIER BUILDING SYSTEMS

8-17-07

SEE DESIGN MANUAL FOR INSULBEAM II HEADER CHART

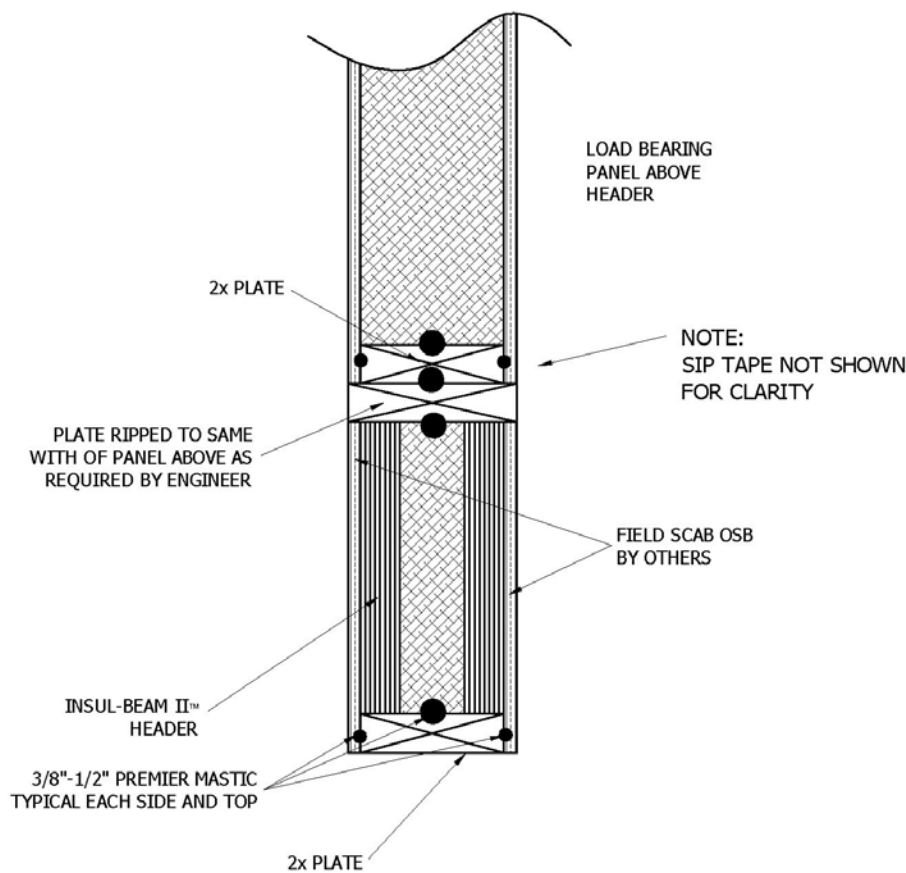

INSUL-BEAM HEADER ABOVE OPENING
PREMIER BUILDING SYSTEMS

11-9-07